

Manual Distance/Time Speedmeter Handbook

A Guide to Type-Approval Procedures
For Manual Distance/Time Speedmeters Used
For Road Traffic Law Enforcement in Great Britain

Dr S R Lewis

Publication No 55/04

POLICE SCIENTIFIC DEVELOPMENT BRANCH
HOME OFFICE CRIME REDUCTION AND COMMUNITY SAFETY GROUP

THE MANUAL DISTANCE/TIME SPEEDMETER HANDBOOK
A GUIDE TO TYPE-APPROVAL PROCEDURES FOR AUTOMATIC DISTANCE/TIME
SPEEDMETERS USED FOR TRAFFIC LAW ENFORCEMENT IN GREAT BRITAIN

DR S R LEWIS

FIRST PUBLISHED 2004

The text of this publication may not be reproduced, nor may talks or lectures based on material contained within the document be given, without the written consent of the Director, Home Office Police Scientific Development Branch.

Published by:

Home Office
Police Scientific Development Branch
Woodcock Hill
Sandridge, St Albans
Hertfordshire AL4 9HQ
United Kingdom

Management Summary

Road traffic law now facilitates the introduction of new methods of speed detection, especially those that permit automatic and unattended detection by using a camera to record the offending motorist. This is one of a series of handbooks which contain a description of the technical requirements to be met for consideration of type-approval of certain types of speedometer which are prescribed devices for the purposes of the road traffic legislation. The handbooks are intended to be a reference for manufacturers wishing to develop or sell existing products to the police service in Great Britain. The handbooks contain not only a list of technical requirements but also guidance on methods of measurement, and the procedures to be followed in seeking type-approval.

This handbook covers speedometers that are manually operated to measure average speed from measurements of the time taken to travel between two positions and measurements of the distance between them. They can also be used to measure the average speed of the vehicle in which the speedometer is installed to infer the average speed of the vehicle it is following.

Contents

		Page
1	INTRODUCTION.....	1
2	SCOPE	2
3	TERMINOLOGY.....	2
3.1	Attended actively operated.....	2
3.2	Average speed	2
3.3	Baseline	2
3.4	Failure	2
3.5	Manufacturer or his agent	3
3.6	Moving check	3
3.7	Stationary check.....	3
3.8	Primary average speed measurement	3
3.9	Secondary speed measurement.....	3
3.10	Elapsed distance.....	3
3.11	Elapsed time	3
3.12	Speedometer.....	3
3.13	Distance/Time speedmeter	3
3.14	Standard vehicle installation.....	3
3.15	Standard-fit.....	4
3.16	Retro-fit	4
3.17	Annual calibration.....	4
3.18	Distance calibration factor	4
3.19	Distance calibration check.....	4
4	GENERAL REQUIREMENTS FOR ELIGIBILITY FOR TYPE-APPROVAL	4
5	OPERATIONAL REQUIREMENTS.....	6
5.1	General	6
5.2	Test signal.....	7
5.3	Segmented display.....	7
5.4	Manual reset	7
6	CONSTRUCTIONAL REQUIREMENTS	8
6.1	Components.....	8
6.2	Power supply.....	8
6.3	Vehicle fitting.....	8

Contents

		Page
7	PERFORMANCE REQUIREMENTS	8
7.1	Storage.....	8
7.2	Working temperature range.....	8
7.3	Robustness	8
7.4	Electromagnetic compatibility.....	9
7.5	Electrostatic discharge	9
7.6	Measuring accuracy	9
	7.6.1 Primary average speed measurement	9
	7.6.2 Secondary speed measurement	10
	7.6.3 Inherent Precision	10
8	MEASURING METHODS.....	10
8.1	General	10
8.2	Speed measurement.....	10
8.3	Inherent precision.....	10
	8.3.1 Test set up	10
	8.3.2 First tests – minimum speed, distance calibration factor and baseline.....	11
	8.3.3 Second tests – maximum speed, distance calibration factor and baseline.....	12
8.4	Speed simulator	12
8.5	Environmental tests.....	12
8.6	Electromagnetic compatibility.....	13
	8.6.1 General arrangements	13
	8.6.2 Modulation.....	14
	8.6.3 Speed simulators test arrangements and set up.....	14
	8.6.4 Conducted immunity test.....	14
	8.6.5 Test limits and frequencies.....	14
	8.6.6 Simulated TETRA immunity test	14
9	TYPE-APPROVAL PROCEDURES	16
Figure 1	EMC test layout.....	18
Figure 2	Plan view of a typical EMC test layout.....	18
Figure 3	Simulated TETRA test dual modulation envelope	19
Figure 4	Inherent error test set up	19

1 INTRODUCTION

- 1.1** Section 20 of the Road Traffic Offenders Act 1988, as originally enacted, provides that evidence from a radar speed detection device is admissible in a prosecution for exceeding the speed limit only if the device is of a type approved by the Secretary of State. This provision was previously laid down in section 90 of the Road Traffic Regulation Act 1984. In practice, this means that all radar speedmeters used by the police for speed enforcement in Great Britain need to be of a type approved by the Home Secretary. To obtain such approval a model speedmeter must, among other things, first meet specific technical requirements laid down by the Home Office Police Scientific Development Branch (PSDB). The first type-approval specification documents for hand-held and across-the-road radar devices were published in 1983 and 1984 respectively by PSDB.
- 1.2** In the White Paper, 'The Road User and the Law', published on the 7th February 1989, the Government set out proposals for enabling more effective use of automatic detection devices in the enforcement of road traffic law, particularly speeding and traffic light offences. Statutory provisions to implement these proposals were included in the Road Traffic Act which received Royal Assent on 25 July 1991 and enacted on 1 July 1992. The technical requirements for radar speedmeters were reviewed by PSDB to take into account recommendations made by the International Organisation of Legal Metrology (OIML) and were expanded to include equipment incorporating photography and designed for unattended and automatic operation.
- 1.3** The opportunity was taken to include in a second edition of the Speedmeter Handbook, published in 1992, the technical requirements for speedmeters using optical methods, road-surface and sub-surface sensors. For greater clarity, it was decided not to continue to incorporate more new types of speedmeter in further editions of the Speedmeter Handbook, but to produce self-standing documents for each type. These are based on the second and subsequent editions of the Speedmeter Handbook. This is such a document and covers speedmeters used to manually measure the average speed of a vehicle from measurements of the time taken to travel between two positions and their distance apart. They are also used to measure the average speed of the vehicle in which the speedmeter is installed to infer the average speed of the vehicle it is following. There is a separate handbook for automatic distance/time speedmeters that measure the average speed from fixed cameras installed above the road.
- 1.4** Prior to 1996 devices of this type, whose accuracy depends critically on the operator, were not subject to Home Office approval. However, following a request by ACPO, a decision was taken in January 1997 that all new devices of this type shall be approved by the Home Office before they are used operationally. Stopwatches used to measure the time to travel a pre-measured distance are not included.

1.5 The type-approval procedure consists of a number of technical performance tests which are carried out on a single production model of the type of speedometer offered for approval by the manufacturer or his appointed agent. The actual testing is carried out by an independent testing laboratory, and is paid for by the manufacturer or his agent. The formal steps necessary to seek approval are described later in section 9 of this guide.

1.6 The technical procedures described in this document replace previous requirements. They are intended as a guide to manufacturers and their agents. The procedures will be updated from time to time to take account of developments in speedometer technology, and amended versions of this guide will subsequently be issued.

2 SCOPE

2.1 The test procedures described here are applicable to equipment used for law enforcement to measure the average speed of a vehicle from manual measurements of the time taken to travel between two positions and their distance apart. It may also be used to infer the average speed of a vehicle from the measurements of the average speed of the vehicle in which the speedometer is installed. Such equipment is designed for attended use only and may be used with an attached video camera to record the measurements.

3 TERMINOLOGY

3.1 Attended actively operated

An equipment designed to be set up and actively operated by a trained user. The accuracy of the evidence from such equipment is verified by the operator in every case at the time of the offence. Such equipment may or may not record an image of an offending vehicle, but its operations are at all times supervised and controlled by the operator whose evidence of the offence is crucial.

3.2 Average speed

A calculated speed obtained by dividing the distance between two datum points by the time measured for a vehicle to travel between them.

3.3 Baseline

The distance between two datum points over which the average speed is measured.

3.4 Failure

A speedometer will be considered to fail a type-approval test if it displays an incorrect reading of speed outside of the tolerance range of error or if it displays a speed when no measurement should be possible. The display of a blank screen or defined symbol in recognition of an incorrect reading is acceptable.

3.5 Manufacturer or his agent

The organisation or company that has developed and/or manufactures the speedmeter or his appointed agent who submits the speedmeter and is party to the type-approval by the Home Office.

3.6 Moving check

An operating mode in which the speedmeter is operated from within a moving vehicle.

3.7 Stationary check

An operating mode in which the speed meter is operated stationary either outside or from within a parked vehicle using a pre measured baseline.

3.8 Primary average speed measurement

The average speed displayed on completion of the measurement and used to provide primary evidence of the average speed of a vehicle.

3.9 Secondary speed measurement

A measurement used to indicate and, when a video camera is attached, record the speed of an operator's own vehicle during an average speed measurement using a moving check for assisting the operator in checking the correct operation of the equipment.

3.10 Elapsed distance

Distance travelled since the start of the distance measurement and displayed with the secondary speed measurement during a moving check.

3.11 Elapsed time

Time elapsed since the start of the time measurement and displayed with the elapsed distance and the secondary speed measurement

3.12 Speedmeter

A device for measuring the speed of road traffic vehicles.

3.13 Distance/Time speedmeter

A speedmeter for measuring the average speed of a vehicle by measuring the time taken to travel between two datum points.

3.14 Standard vehicle installation

A vehicle installation, which in addition to the speedmeter, has all its electronic components and their interconnections, installed to a common defined standard.

3.15 Standard-fit

The speedmeter is installed as an integrated part of a standard vehicle installation and is to be approved for use only on vehicles of the same model and standard vehicle installation tested.

3.16 Retro-fit

The speedmeter is installed additional to a vehicle's own installation and is to be approved for use independently of the vehicle used and the vehicle's own installation and only when there are no radio transmissions from radios installed or taken into the vehicle.

3.17 Annual calibration

An annual check of the absolute accuracy of the measurements performed by the speedmeter using test equipment calibrated to national standards.

3.18 Distance calibration factor

The number of odometer pulses generated by the vehicle in which the speedmeter is installed over one mile and used to compute the distance travelled during a moving check.

3.19 Distance calibration check

A frequent check on the accuracy of the speedmeter's distance calibration factor using the speedmeter to measure the number of odometer pulses generated by the vehicle in which it is installed measured over a known distance. The vehicle is driven over a straight base line whose length has been pre-measured with instruments calibrated to national standards and certified by a qualified engineer.

4 GENERAL REQUIREMENTS FOR ELIGIBILITY FOR TYPE-APPROVAL

4.1 The supplier shall provide free of charge to the testing laboratory carrying out the type-approval, a speedmeter of the type intended for sale, together with a written technical description of its operation and full circuit diagram.

4.2 The Home Office or its agents will accept no liability for breakage or damage.

4.3 The model type shall be indelibly marked on the outside of the meter (or its component parts if so assembled), together with a serial number which shall be unique to that instrument.

4.4 All models, if approved, shall be numbered consecutively.

- 4.5** Any system software or firmware shall be labelled with a version number, and either a copy of the program or a sample of the memory shall be left with the Home Office.
- 4.6** Once type-approval has been granted the manufacturer or his agent shall not change either the value or type of the components used, or alter the circuit, or the pre-programmed memory of the speedmeter, without permission of the Home Office.
- 4.7** The speedmeter shall be calibrated annually, and a certificate should be issued to this effect and held by the police. A visible sticker showing the date of calibration should be fixed to the meter.
- 4.8** Any repair or calibration shall be carried out by the manufacturer, his appointed agent, or a suitably qualified technician, offering appropriate evidence of technical and professional competence. Such persons shall keep accurate records that shall be open to inspection by the Home Office.
- 4.9** All equipment used for calibration (but not for repair) shall be certificated annually by a competent body with equipment traceable to national standards.
- 4.10** A handbook or a set of written instructions for the use of the operator shall be provided with the instrument at the time of type-approval testing. The instructions shall be dated and any subsequent changes sent to all users, including the Home Office.
- 4.11** Any requirement for goods or materials to comply with this specification shall comply with :
- 1 A relevant standard or code of practice of a national standards body or equivalent body of any member state of the European Community.
 - or 2 Any relevant international standard recognised for use in any member state in the European Community.
 - or 3 A relevant technical specification acknowledged for use as a standard by a public authority or any member state of the European Community.
 - or 4 Traditional procedures of manufacture of a member state of the European Community where these are the subject of a written technical description sufficiently detailed to permit assessment of the goods or materials for the use specified.
 - or 5 A specification sufficiently detailed to permit assessment for goods or materials of an innovative nature (or subject to an innovative process of manufacture such that they cannot comply with a recognised standard or specification) and which fulfil the purpose provided by the specified standard.

Provided that the proposed standard, code of practice, technical specification or procedure of manufacture provides in use equivalent levels of safety, suitability and fitness for purpose.

5 OPERATIONAL REQUIREMENTS

5.1 General

- 5.1.1** The speedmeter shall have three easily operated and clearly marked switches, two for independently starting and stopping the distance and time measurements and a combined one for starting or stopping both measurements simultaneously. The switches shall be ergonomically designed for reliable and separate operation, with the distance switch on the same level and to the left of the time switch. The combined switch shall be positioned between and immediately above these switches.
- 5.1.2** For a moving check, the distance measurement shall commence on a single press of either the distance switch or the combined switch and shall stop on the next single press of either of them. Similarly the measurement of time shall commence on either a single press of the time switch or the combined switch and shall stop on the next single press of either of these. The speedmeter shall only output a primary average speed measurement after both the time and distance measurements have been stopped and the distance measurement is equal to or exceeds 0.125 miles. At shorter distances it shall only output the distance measured.
- 5.1.3** For a stationary check, the speedmeter shall enable the user to either manually enter a pre-measured baseline or if equal to or exceeding 0.125mile, use the last distance measured using the speedmeter for that purpose or from a completed moving check. After selection of this mode any operation of the distance switch shall not effect the measurement. For a manually entered base line and before the user can enter its value, the user shall be required to enter the prevailing speed limit. Unless the speed limit is equal to or less than 40mph the user shall only be able to enter values that are equal to or exceed 0.125 miles. If the speed limit is 40 mph or less the user shall be able to enter values that are equal to or exceed 0.07 miles.
- 5.1.4** When the speedmeter is installed in a vehicle, a pre-measured base line equal to or exceeding 0.125miles can be used in a moving check to produce evidence of its own vehicle's average speed. The speedmeter shall automatically disable display of the primary average speed measurement when the entered baseline is less than 0.125miles and the vehicle is moving. In this mode one press of the time switch or the combined switch shall begin a measurement of both the time and distance and both the time and distance measurements shall automatically stop when the elapsed distance equals the pre-set base line value.
- 5.1.5** Whilst the moving check mode is selected, the speedmeter shall display a secondary speed measurement while the check is not being undertaken. During a check it shall in addition show the elapsed distance in miles with a resolution of 1/1000 mile and the elapsed time in seconds to a resolution of 10 millisecond. In any mode of operation on completion of a valid check it shall display with the same resolution the primary measured average speed, the length of the measurement base line used and the duration of the measurement. It shall additionally show the date and time of the offence in the following order: day, month and year and the time the measurement was completed in hours, minutes and seconds*. For a moving check it shall also indicate that the measurement relates to the speed of the vehicle in which the speedmeter is installed whenever either a pre-measured distance is used or the combined switch is used to both start and stop the measurement.

- 5.1.6** If connected to a video camera, the video recording shall clearly show the target vehicle while it remains in the field of view of the camera. Every image recorded within the duration of the measurement shall include the same information imposed on the image as that displayed on the speedmeter.
- 5.1.7** The speedmeter shall have a distance calibration factor that can only be set by the user undertaking and completing a distance calibration check. The speedmeter shall only permit operation when the distance calibration factor is equal to or exceeds 1760 or if greater, the manufacturers specified minimum distance calibration factor and when the last distance calibration check has been undertaken within 7 days. It shall otherwise require a distance calibration to be undertaken before any other checks can be performed. It shall not be possible to undertake a distance calibration check using a calibrated distance of less than 0.5mile.
- 5.1.8** The speedmeter shall be provided with an on/off switch and ‘power on’ and ‘battery low’ indicators.
- * The indication of time to the nearest minute is acceptable.

5.2 Test signal

The instrument shall be provided with in-built test signals to simulate a measurement. The test signals shall be independent of the measuring circuits, and shall be capable of checking the function and accuracy of all circuits from the odometer input and clock output onwards. The test signal may operate automatically when the equipment is switched on, but it shall also be available for manual operation. When the test signal operates, the display shall clearly show that a test signal has been generated. The clock used for this test shall also continuously monitor the accuracy of the source clock for the time measurement and shall disable measurement whenever they differ by more than +/- 0.02% over a period of 500sec.

5.3 Segmented display

If a segmented display is used there shall be a means of checking that all segments are functioning.

5.4 Manual reset

On completion of a check the last reading shall remain visible on the display until cleared by the user by either pressing a reset button or initiating another check with the time, distance or combined switch. For a stationary check, on pressing the reset button or initiating another check, the average speed reading shall be removed or zeroed. When the display is reset or another measurement commenced, it shall not be possible to recall to the display any previous reading.

6 CONSTRUCTIONAL REQUIREMENTS

6.1 Components

The speedmeter shall be constructed of good quality components that are clearly marked with their type number or value, either in writing or by a recognised code. Any sensor cables shall have an identifying mark.

6.2 Power supply

The speedmeter shall only operate from its own battery supply. When the speedmeter supply is set at the normal voltage and the supply is gradually reduced below the minimum working voltage, no erroneous reading shall appear. Speed indication shall be inhibited when the power supply voltage varies beyond the design limits.

6.3 Vehicle fitting

Equipment operating installed in a vehicle shall use a separate battery to power the speedmeter, and any charging circuit from the vehicle power supply shall be automatically disconnected when the speedmeter is switched on. Speedmeters that are retrofitted shall use optically isolated odometer inputs. The vehicle installation shall either facilitate removal of the speedmeter for annual calibration or provide access to test connections on the speedmeter that enable the annual calibration to be performed in situ.

7 PERFORMANCE REQUIREMENTS

7.1 Storage

7.1.1 The speedmeter shall, when out of service, be capable of storage in adverse conditions.

7.1.2 They shall be held for at least 3 hours at -25° and then +70°C, with low humidity. The units shall then be allowed to return to room temperature and tested to ensure correct operation.

7.2 Working temperature range

7.2.1 The equipment shall function within specification over a temperature range of at least -10° to + 50°C, with 80% humidity above 20°C. The temperature shall be varied in 5° steps, and the equipment left for 30 minutes or longer to obtain thermal equilibrium. The equipment shall function correctly at each temperature step.

7.2.2 The equipment shall have some form of sensor to prevent the equipment operating beyond the working temperature range.

7.3 Robustness

The equipment shall be constructed so as to be fit for its purpose.

All parts of the equipment that may be exposed to the weather shall comply with the requirement of BS EN 60529:1992 ingress protection test - classification IP 55 for water ingress and dust protection.

7.4 Electromagnetic compatibility

The equipment shall be capable of operating without indicating an erroneous reading as follows:

- a. in fields of at least 10V/m from 80 to 2000 MHz .
- b. in the presence of common mode currents from 27 MHz –100 MHz to Level 2 of Table 1 in EN 61000-4-6.
and also, if designed for retro fit in a vehicle and for use out of a vehicle,
- c. in simulated TETRA fields as defined in section 8.6.6 of at least 20V/m.
or if being considered as a standard fit
- d. in simulated TETRA fields as defined in section 8.6.6 at a level specified by PSDB for that installation.

For (a) and (c) or (d) the basic test procedure defined in EN 61000-4-3 shall be used. For (b) the basic common mode injection test procedure defined in EN 61000-4-6 shall be used.

Some of the requirements may be met by complying with the provisions of Directive 89/336/EEC (Electromagnetic compatibility). Under these circumstances equipment complying with the Directive and which has already been granted the certificates of conformity provided for therein shall be exempt from the parts of the type approval procedure covered by the Directive.

7.5 Electrostatic discharge

The speedmeter shall be tested in accordance with EN 61000-4-2: 1995. At least ten single discharges shall be applied to the exposed surface of each separate part of the meter.

For permanent installations, tests may be performed in the final installed position.

A test voltage of 4 kV shall be employed i.e. at level 2.

7.6 Measuring accuracy

7.6.1 Primary average speed measurement

The speedmeter shall be assessed using a vehicle fitted with both the speedmeter under test and a reference speed measuring system having an accuracy of at least ± 1 mph which can output both spot and average speeds. A vehicle that generates between 1760 and 3520 odometer pulses a mile or generates a distance calibration factor equal to or less than twice the minimum specified by the manufacturer shall be used. A divider may be used to reduce the pulse rate to be within this range. The speedmeter under test shall be set to measure the speed of the vehicle in which it is installed using a moving check over a pre-set distance of 0.125 miles as described in section 5.1.4. Its accuracy shall be assessed by comparing the primary average speed readings from the speedmeter with those from the reference system. Immediately before the tests commence a distance calibration check shall be undertaken using a calibrated baseline length of 0.5 mile to update the distance calibration factor. Measurements at different speeds, up to the maximum stated by the manufacturer, shall be made. Simulated

speeds may be used for speeds above 120mph. The speedmeter shall give a positive error no larger than + 2 mph (or +3% above 66 mph) and a negative error of no greater than 5 mph or 10 % above 50 mph (see 8.2).

7.6.2 Secondary speed measurement

The displayed secondary speed measurement shall remain within 10% of the spot speeds measured by the reference system. If the equipment under test includes a video recording system then it shall be used to assess whether the recorded secondary speed measurement remains within 10% of the spot speeds measured by the reference system.

7.6.3 Inherent Precision

The speedmeter shall operate with accuracy of +/- 1mph or less when using simulated odometer pulses and time, distance and/or combined switch activation activated independently of the odometer pulses over the following ranges:

Average speeds from 20mph up to the manufacturers stated maximum

Distance calibration factors from 1760 or the minimum specified by the manufacturer up to 65536

Baseline lengths equal to or greater than 0.07miles

Moving checks with average speeds equal to the manufacturer's specified maximum over elapsed time duration up to and including 10 minutes duration.

These shall be tested using the test conditions defined in section 8.3.

8 MEASURING METHODS

8.1 General

This section describes suitable methods of measurement for carrying out the tests described in previous sections. It is recommended that the methods be followed to ensure uniformity and repeatability of testing. All measuring procedures shall be recorded in the test report.

8.2 Speed measurements

A road or track test shall be performed by driving the car fitted with both the speedmeter under test and the reference speedmeter calibrated to within 1 mph (1% above 100 mph), at various speeds between 20 mph and the manufacturers stated maximum or 120mph if less. At least 100 measurements of the primary average speed shall be taken as described in section 7.6.1.

If a video recording system is attached it shall be used to check the secondary speed at five points, approximately equally spaced, during each primary average speed measurement. Otherwise a video camera and recorder shall be temporarily installed in the car to record the secondary speed measurement displayed on the speedmeter.

8.3 Inherent precision

8.3.1 Test set up

For these tests the speedmeter may be tested not installed in a vehicle. The tests may be done using a set up similar to that shown in Figure 4. If the speedmeter includes a

video recording system it shall be used to record the results of the tests. Otherwise a separate video camera shall be used to monitor and record the displayed information.

With the speedmeter set to undertake a moving speed check, the test requires the automatic operation of the combined switch to start and stop the check after specified delays with respect to the falling edge of their preceding odometer pulses. Delays of 7/16 and 15/16 of the odometer pulse period are required for the start (i.e. delay (a) in figure 4) and delays of 1/16 and 9/16 are required for the stop of the check (delay (b)). A delay (delay (c)) is also required so that the time between the start and stop of the check is just sufficient to ensure that the simulated minimum base line length is just exceeded.

Simulated odometer pulses are applied to the speedmeter during the test and derived from a pulse generator operating at sixteen times the required odometer pulse frequency. The frequency of the pulse generator shall be monitored with a calibrated frequency counter.

8.3.2 First tests – minimum speed, distance calibration factor and baseline

Three moving check measurements of the average speed of the speedmeter's own vehicle shall be simulated as described below using the minimum speed, distance calibration factor and base line.

The speedmeter shall first be set with a distance calibration factor equal to either 1760 or the manufacturer's specified minimum by operating the calibration check and applying this number of simulated odometer pulses.

The speedmeter shall then be set to operate a moving check. Simulated odometer pulses shall be applied on the odometer input at a fixed frequency, f Hz, to simulate the speedmeter installed in a vehicle travelling at a constant 20mph. The frequency f as a function of speed is given by equation (1) below

$$f = v \cdot k / 3600 \quad (1)$$

where: f is the simulated odometer pulse frequency in Hz

v is the simulated constant speed in mph

k is the distance calibration factor in pulses per mile.

For example for a minimum distance calibration factor of 1760, the simulated odometer pulse frequency for a simulated speed of 20mph is 9.77778 Hz.

For the first measurement, the combined switch shall be manually operated to start a measurement and operated again to stop the measurement when the elapsed distance exceeds 0.125 miles. The primary average speed displayed on the speedmeter at the end of this check shall be recorded as reading number 1. The displayed information shall also be checked to ensure it shows that the measurement relates to the speed of the vehicle on which the speedmeter would have been installed.

To simulate a moving check started and stopped by the operation of the combined switch operated over a distance that just exceeding the minimum base line length of 0.125 miles, a delay (delay (c)) set equal to the nearest number of pulses that exceed one eighth of the set minimum distance calibration factor i.e. $k/8+1$ pulses, is applied as shown in Figure 4. The set up shall enable delay (a) and delay (c) to be started simultaneously by activation of switch A. Delay (a) shall have a pre-selected delay of 7 or 15 pulses from the pulse generator before it activates the combined switch when connected via switch B. Delay (b) will be triggered from the pulse delayed by delay (c) before it activates the combined switch when connected via switch B. Delay (b)

shall have a pre-selected delay of 1 or 9 pulses from the pulse generator before it activates the combined switch.

Switch B, the switch between the outputs of delay (a) and delay (b) and the combined switch, may be operated manually within 20 seconds of the measurement having commenced.

With this set up the first tests shall be operated twice with the following delay settings:

Setting	Delay a	Delay b	Reading N ^o
1	15	1	2
2	7	9	3

The primary average speed reading shall be recorded for setting 1 as reading number 2 and for setting 2 as reading number 3.

8.3.3 Second tests – maximum speed, distance calibration factor and baseline

Three moving check measurements of the average speed of the speedmeter's own vehicle shall be simulated as described below using the maximum speed specified by the manufacturer, the required maximum distance calibration factor and base line.

The calibration check shall be used to set the distance calibration factor in the speedmeter under test to the required maximum of 65536. The simulated odometer pulse frequency shall be adjusted to simulate the vehicle in which the speedmeter is installed travelling at the maximum average speed specified by the manufacturer for the speedmeter to measure. The required frequency is given by formula (1).

The above simulated moving check shall then be repeated with delay c set to 600 seconds and delays a and b set first to setting 1 and then repeated with delays a and b set to setting 2. The primary average speed reading for setting 1 shall be recorded as

8.4 Speed Simulator

After a distance calibration check using simulated odometer pulses has been done to set a calibration factor at 3520, a constant speed may be simulated for laboratory tests by setting the speedmeter to do a moving check and applying simulated odometer pulses at the rate given by formula (1). The displayed secondary speed measurement shall display the simulated speed and a primary average speed reading shall be simulated by operation of the combined switch with a time separation sufficient to ensure the simulated distance is greater than 0.125 mile.

8.5 Environmental tests

8.5.1 At each temperature step in the working temperature range the equipment shall be checked by operating the manual test and one simulated primary average speed measurement.

8.5.2 Care shall be taken to ensure that any fans, thermostats, or other electronic control devices associated with the environmental chamber, do not cause spurious readings during the testing cycle.

8.6 Electromagnetic compatibility

8.6.1 General arrangements

- 8.6.1.1** The test arrangement is applicable to both radiated and conducted tests. The object of the tests is to confirm that the speedometer is capable of operating in the presence of electromagnetic fields without recording an erroneous speed reading.
- 8.6.1.2** The layout of the speedometer shall be representative of the normal operating conditions, in so far as this will permit a repeatable measurement. The measurement shall be carried out in screened test facilities described in EN61000-4-3 with the equipment set up as intended for use. The field uniformity criteria of EN61000-4-3 apply for the radiated immunity test.
- 8.6.1.3** The equipment to be tested is placed centrally in the calibrated test area. The device and its wiring are mounted on a conducting bench 0.8m above and connected to the ground plane (figure 1). Devices designed to operate on a tripod shall be adjusted to be 1m above ground.
- 8.6.1.4** Any associated cable bundles/wiring shall be arranged in general accordance with EN61000-4-3. At least 1m cabling from the device to the test facilities power supplies must run in the calibrated area. Any interconnecting cabling, remote control cabling or camera cabling will be treated as follows:
- the manufacturer's specified cable types and connectors shall be used.
 - when the manufacturer's specification requires a wiring length of less than 3m, then the specified length shall be used. The wiring shall be bundled low-inductively to 1m length.
 - when the specified length is greater than 3m then the illuminated length shall be a minimum of 1m. The remainder shall be run outside the calibrated area on the floor de-coupled at the 1m point by the use of lossy tubes. However in the case of remote control cables, the remote control unit must be in the calibrated area as shown in Figure 1. Therefore the cable length excess greater than 1m shall be zig-zagged on the floor parallel to and behind the odometer pulse simulator.
- 8.6.1.5** In at least one orientation of the device the wiring shall be arranged parallel to the calibrated uniform area of the field.
- 8.6.1.6** The exposed wiring shall be run in a configuration that simulates as closely as possible the manner it is run in operation.
- 8.6.1.7** All wiring running on the floor in the calibrated test area shall be spaced 0.1m from the floor by means of low dielectric spacers.
- 8.6.1.8** Any changes found necessary in the layout shall be recorded in the test report.
- 8.6.1.9** The device under test shall be irradiated by both horizontal and vertical polarised fields from 4 orthogonal illumination angles. Figure 2 shows a plan view of a typical test arrangement.

8.6.2 Modulation

8.6.2.1 All test signals shall be 90% amplitude modulated with a square wave signal. During these tests a speed simulator shall be used to monitor the correct operation of the equipment under test.

8.6.2.2 A modulation frequency shall be used which is at the odometer pulse frequency that would be needed to simulate a vehicle travelling at a different speed from that is being used on the speed simulator. For example 30 mph may be used for the speed simulation and 40 mph used to determine the modulation frequency. The modulation frequency is given by formula (1).

8.6.3 Speed simulators Test Arrangements and Setup

8.6.3.1 Care shall be taken to ensure that the connection of the simulator does not degrade the immunity of the equipment under test.

8.6.3.2 The display of the device shall be monitored throughout the test period, and any erroneous readings or inconsistency in behaviour noted together with the appropriate test frequency and field intensity.

8.6.4 Conducted immunity test

8.6.4.1 The test is conducted in basic accordance with EN61000-4-6 with the following test method deviations:

- The clamp injection procedure is to be used with the signal being applied to the total cable bundle i.e. common mode injection. The signal is injected at each electronic unit of the device under test connector by connector. The current probe monitoring the injected current is placed 0.05m from the device's connector on the bundle under test. The injection clamp is placed 0.05m from this.
- The modulation and limits are as defined in sections 8.6.2 and 7.4

8.6.5 Test limits and frequencies

8.6.5.1 The tests limits defined in section 7.4 for a) the standard radiated immunity test and b) the standard conducted immunity test are in terms of the cw value of the signal; the modulation being applied on top giving peak readings 90% higher than the cw limit.

8.6.5.2 The RF signal shall be applied at each test frequency at the test limit for a time long enough to fully operate the device under test. The frequencies shall be stepped incrementally across the test range with a step size not exceeding 1% of the previous frequency. If any effect is observed, the applied signal shall be reduced by 12dB and increased in steps of 3 dB until the required test level is reached. The level at which the threshold of any effect is observed, shall be logged and recorded in the test report.

8.6.6 Simulated TETRA immunity test

8.6.6.1 The device under test shall be irradiated with both horizontal and vertically polarised fields from four orthogonal illumination angles in turn.

- 8.6.6.2** The device shall be tested at each of the test frequencies specified in section 8.6.6.3 by increasing the field, at each test frequency, from a minimum level of 12dB down from the appropriate test limit in steps of 3dB until the test level is achieved. The level at which the threshold of any effect is observed shall be logged and recorded in the test report.
- 8.6.6.3** The test frequencies to be used for this test are:
- 380, 385, 390, 395, 400, 405, 410, 415 and 420MHz.
- The tolerance on these frequencies is ± 0.1 MHz.
- 8.6.6.4** The test limit given in section 7.4 is in terms of the peak value of the modulated signal as measured using a peak detector calibrated in terms of the equivalent rms sine wave value that would give the same reading. This is the standard calibration for all peak detector functions on EMC receivers or spectrum analysers.
- The modulation to be applied shall be an 18kHz square wave modulation with a depth >98% additionally gated on and off at 17Hz. The duty cycle shall be 50%. This is shown in figure 3.
- 8.6.6.6** The test limits are in terms of the peak value of the signal when measured using the peak detector function of the measuring receiver/spectrum analyser. This is calibrated in terms of the equivalent rms value of a sine wave as defined by:
- “When measuring a modulated signal, the bandwidth of the measuring receiver should be set wide enough to capture the total energy of the signal. The amplitude reading as measured by the peak detector function is noted. The unknown signal is disconnected and a sine wave signal at the same frequency fed in. Its amplitude is adjusted until the same reading is produced on the measuring receiver. This amplitude is expressed in terms of the rms value of the sine wave e.g. a 1 volt rms sinewave input will give an indicated measurement of 1 volt. This will not change if the signal is switched on and off, the peak reading will still be 1 volt hence the term peak rms.”
- 8.6.6.7** The characteristics of the equipment to be used to measure the amplitude of the applied susceptibility test are:
- The amplitudes associated with the test limits are based on the peak of the rms envelope over the complete modulation period.
 - Amplitude measurements shall be made in a manner that clearly establishes the peak amplitude of the modulated waveform.
 - The measuring instrument must have a fast enough time response to respond to signal amplitude variations. A spectrum analyser may be used.
 - The detection, resolution and video bandwidths of the measuring instrument must be wider than the modulating frequency.
 - The measurement bandwidth shall be increased until the amplitude of the measured signal does not change by more than 1dB for a factor of three change in bandwidth. This bandwidth setting shall then be used for the test. At the proper setting the individual modulation side bands will not be resolved.
- 8.6.6.8** It is important to meet these requirements especially when measuring modulated signals. The use of a spectrum analyser for signal measurement during susceptibility testing does provide advantages over power meters or receivers as it allows a more direct visual check on the quality of the applied signal during the testing. It provides

direct indication if the signal source is becoming non-linear, or generating spurious signals. Sometimes, when mismatched, TWT amplifiers have been found to produce parasitic high power oscillations even with no input drive at a frequency that may be well removed from the required test frequency. Regular checks should be made on the quality of the test signal, and presence of spurious signals.

9 TYPE-APPROVAL PROCEDURES

9.1 Persons seeking type-approval should first arrange for the equipment to be demonstrated to the ACPO Road Policing Enforcement Technology Committee, who will arrange for a practical assessment by one or more police forces. Enquiries should be made to:

The Secretary,
ACPO Road Policing Enforcement Technology Committee
Association of Chief Police Officers
25 Victoria Street
London SW1H 0EX.

Only when this assessment has been satisfactorily completed, and any necessary modifications made to the speedometer, should the device be offered for formal type-approval. Requests for type-approval should be made to:

Road Crime Section
Public Order and Crime Issues Unit
Home Office
5th Floor
50 Queen Anne's Gate
London SW1H 9AT.

9.2 Road Crime Section will normally recommend test laboratories to carry out type-approval testing in accordance with procedures laid down by PSDB*. Manufacturers or their approved agents are expected to bear the full costs of the private test laboratory's evaluation work. On completion of their work, the private test laboratory will submit a report on their evaluation of the device to PSDB. PSDB will submit the results to Road Crime Section for consideration to be given to obtaining the agreement of the Secretary of State for the Home Department to formal type-approval.

* The results of checks and tests carried out by the bodies and laboratories of other Member States, including in particular those in conformity with EN 45000, will be taken into consideration where such results provide a level of accuracy, fitness and suitability for purpose equivalent to the results of tests carried out in the United Kingdom, and where such bodies and laboratories offer suitable and satisfactory guarantees of technical and professional competence and independence.

9.3

To back up type-approval, Road Crime Section prepares a supporting agreement for signature by the manufacturer and Home Office officials which is primarily directed at preventing the manufacturer from altering the device in question in any way without the prior approval of the Secretary of State. The manufacturer shall agree:

- (i) not to change the device without the agreement of the Secretary of State;
- (ii) to ensure that the type and serial number of each device is clearly identified by an indelible marking;
- (iii) to ensure that the serial number is unique to each device and that each device is numbered consecutively;
- (iv) to ensure that any repair or calibration facility relating to the device is open to inspection;
- (v) supply free of charge to the Secretary of State a full circuit diagram of the device with all the circuit components clearly indicated; and, if required;
- (vi) to supply a device free of charge to the Secretary of State. The Secretary of State shall not be responsible for any damage caused to the device whilst it is in his possession.

This agreement must be signed by the manufacturer prior to the Home Secretary signing the formal type-approval document.

FIGURE 1: EMC test layout

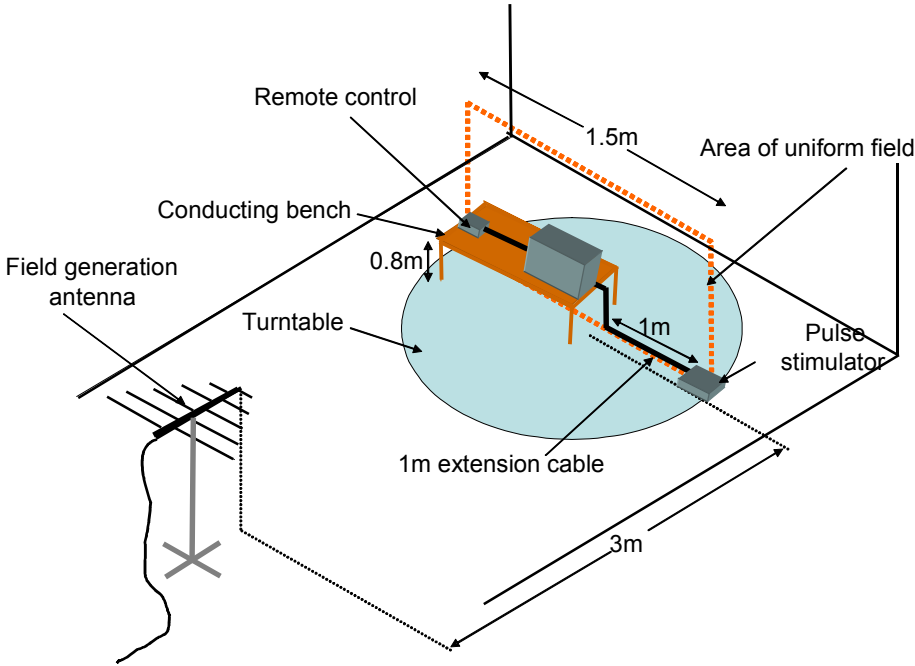

FIGURE 2: Plan view of a typical EMC test layout

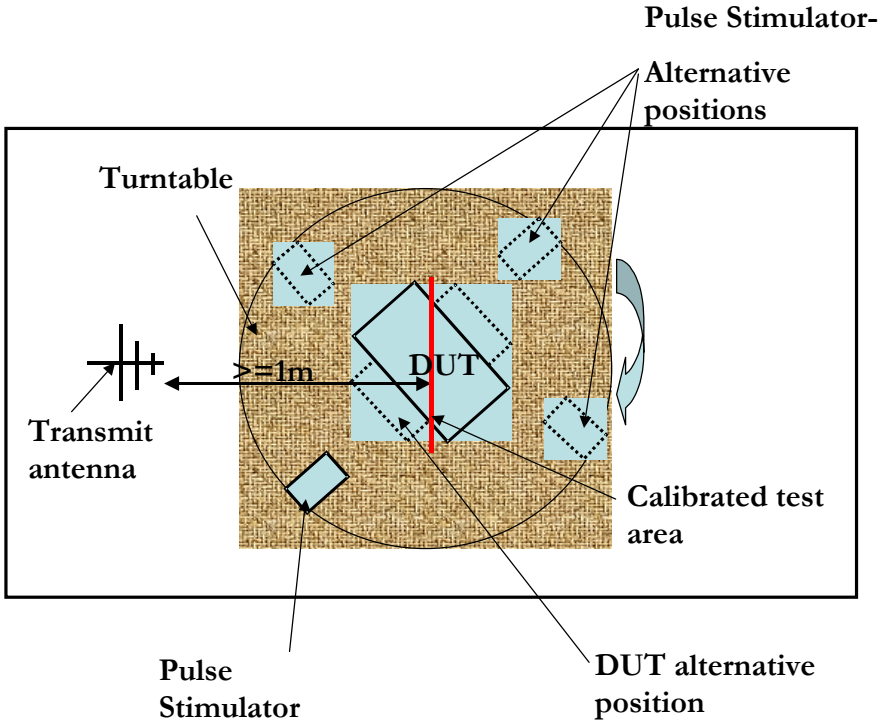

FIGURE 3: Simulated TETRA test dual modulation envelope

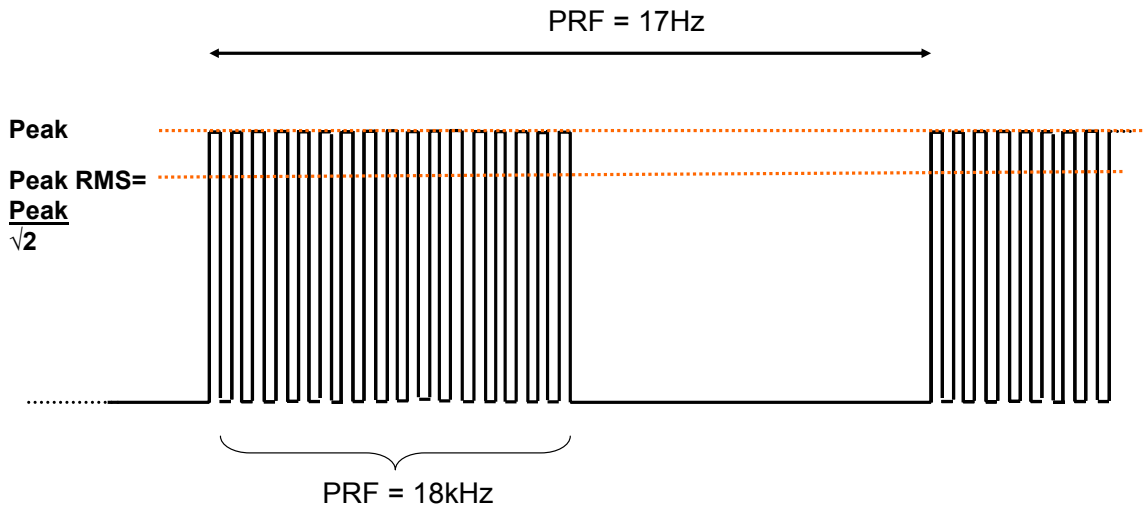

FIGURE 4: Inherent error test set up

